

SAFEGWAY LED TWIN EMERGENCY LIGHT



DL 2018NM



Features and Application

The self-contained Safeway LED Twin Emergency light is ideal for indoor installations. Utilising LED lamps, the compact fixture is energy saving and can be easily installed in public areas such as staircase landings, walkways, etc. Its twin head lamps can be easily rotated 360 degrees and allows flexible positioning of the lights into various directions.



Technical Data

Mode of Operation	Non-maintained
Lamp	2 x 1 watt High Flux White LED
Mains Supply	230V AC 50/60Hz
Power Consumption	2VA
Battery	Maintenance-free High Temperature Nickel Cadmium
Charger	Fully automatic
Charging Monitor	Ø 5mm Green LED
Recharge Period	24 hrs
Testing Facility	Test-switch for independent testing
Emergency Duration	2 hrs
Safety Feature	Low-voltage cut-off to prevent over-discharge of battery
Construction	Injection moulded, fire retardant polycarbonate housing
Weight (Nett/Gross)	0.8 kg / 0.9 kg
Compliance	SS563; SS263 pt.2; IEC 61347-2-7; IEC 61347-2-13; IEC 61347-1; IEC 62384; IEC 62301; IEC 62471
Installation	Wall or pendant mounting
Cable Entry	Standard 20mm Ø knockout hole
Warranty	1 year

Dimensions (mm)

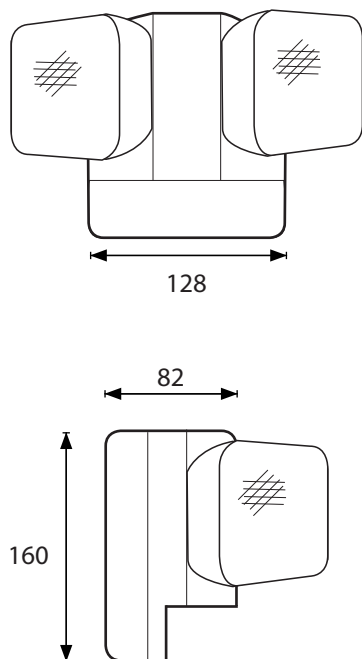

Ordering Information

MODEL	LAMP
DL 2018NM	2 x 1 watt High Flux White LED