

TWIN-FLOOD EMERGENCY LIGHT WEATHERPROOF TYPE



DL 210NM (WP)



Features and Application

The robust and self-contained DL 210NM (WP) Twin-Flood Emergency Light weatherproof type is perfect for outdoor installations. The DL 210NM (WP) is durable, fire-retardant and adjustable for range of optimum projection in upmarket retail stores, supermarkets, factories and all escape routes. The housing is poly-carbonate with a beige finish.



Technical Data

Mode of Operation	Non-maintained
Lamp	2 x 6V 10 watt Tungsten Halogen lamp
Operating Temperature	ta 40°C
Mains Supply	230V AC 50/60Hz
Power Consumption	4VA
Battery	Maintenance-free Sealed Lead Acid Battery
Charger	Fully automatic
Charging Monitor	Ø 5mm Green LED
Recharge Period	24 hrs
Testing Facility	Push-off Test-switch for independent testing
Emergency Duration	>2 hrs
Safety Feature	Low-voltage cut-off to prevent over-discharge of battery
Construction	High-impact plastic housing
Flammability Class	Self-extinguishing
Weight (Nett/Gross)	3.5 kg / 3.7 kg
Compliance	SS563 ; SS263 pt.2 ; IEC 60598-2-22; IEC 61347-2-7; IEC 61347-1
Installation	Wall or pendant mounting
Cable Entry	1 x 20mm Ø knockout hole
Warranty	1 year

Dimensions (mm)

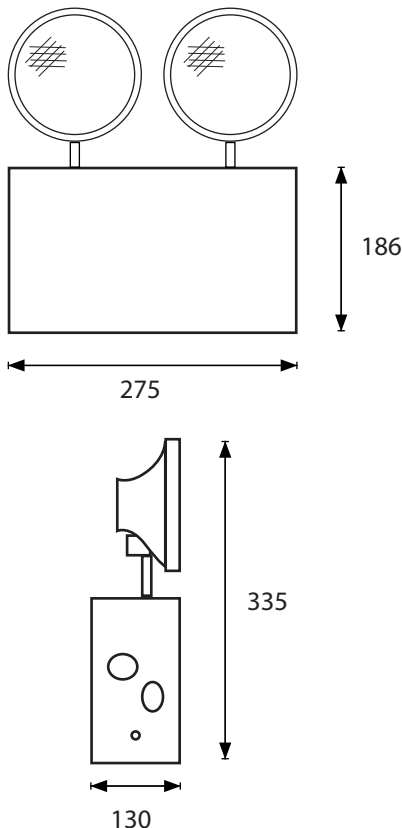

SPECIFICATIONS SUBJECT TO CHANGES WITHOUT PRIOR NOTICE.

Ordering Information

MODEL	LAMP
DL 210NM (WP)	2 x 10 watt Tungsten Halogen