

NEW

LED TWIN-FLOOD IP65 WEATHERPROOF EMERGENCY LIGHT

EmDL 203NM WP

PLS Listed
Emergency
Lighting

PSB Singapore



Class I

Features and Application

- Weatherproof housing with dual 3W LED self-contained emergency light.
- Adjustable lamp heads to project light in desired position.
- Robust, fire-retardant and weatherproof polycarbonate housing ideal for outdoor operation.
- Weatherproof IP65 rated TÜV SÜD PSB certified, ideal for outdoor installations in dusty, humid and corrosive environments including car parks, loading bays, workshops, laboratories and corridor areas.



EMERGENCY LIGHT

Technical Data

Mode of Operation	Non-maintained
Lamp	Samsung 2 x 3W High flux white LED
Operating Temperature	ta 0°C ~ 50°C
Mains Supply	230V AC 50Hz/60Hz
Power Consumption	< 2W
Battery	High temperature NICD battery
Charger	Fully automatic
Charging Monitor	Ø 5mm green LED
Lamp Circuit Continuity Monitor	Ø 5mm green LED
Recharge Period	24 hours
Testing Facility	Test-switch for independent testing
Emergency Duration	3 hours
Safety Feature	Low-voltage cut-off to prevent over-discharge of battery
Construction	Polycarbonate
Weight (Nett/Gross)	1.8 kg / 2 kg
Compliance	SS 563-2/A1:2013; SS IEC 60598-2-22:2016 SS IEC 60598-1:2016
Installation	Wall or pendant mounting
Cable Entry	1 x 20mm Ø knockout hole
IP Rating	IP65 rated TÜV SÜD PSB certified *
Warranty	1 year

Dimensions (mm)

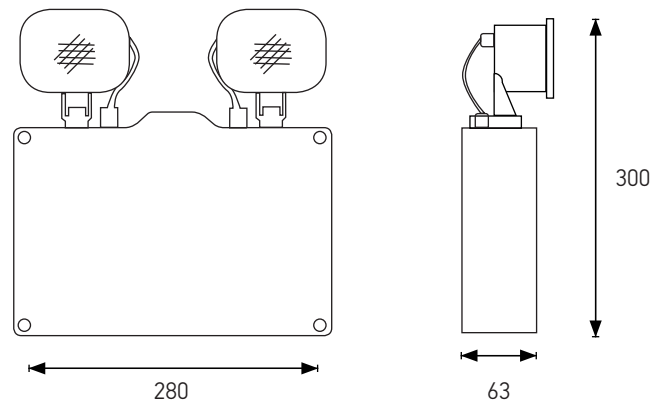

Ordering Information

MODEL	LAMP
EmDL 203NM WP	Samsung 2 x 3W High flux white LED

Remarks

* For Weatherproof (IP65) installation, a cable gland (PG9 to PG13.5) is required for the AC incoming cable entry to ensure IP65 rating.