

EmEX R1602M / RM Recessed Series

X SLIM LED EMERGENCY EXIT SIGN

Features and Benefits

- New slim housing LED emergency exit signs with recess plate and bracket.
- Available in Exit or Running Man signage.
- Designed for easy installation and maintenance.
- Samsung LED lamps provide high efficiency, durability and low energy consumption.



EmEX R1602M

EmEX R1602RM



Technical Data

Mode of Operation	Maintained
Lamp	Samsung 2W High flux white LED
Operating Temperature	ta 0°C ~ 50°C
Mains Supply	230V AC 50Hz/60Hz
Power Consumption	< 4W
Battery	High temperature Ni-Cd battery
Charger	Fully automatic
Charging Monitor	Ø 5mm green LED
Recharge Period	24 hours
Testing Facility	Test-switch for independent testing
Emergency Duration	3 hours
Safety Feature	Low-voltage cut-off to prevent over-discharge of battery
Construction	Electro-galvanised steel casing with epoxy powder coating
Weight (Nett/Gross)	1.5 kg / 1.7 kg
Compliance	SS 563-1:2010 SS 563-2:2010/A1:2013 SS IEC 60598-2-22:2016
Installation	Recessed mounting
Cable Entry	3 x 20mm Ø knockout hole
IP Rating	IP20
Legend	White text/graphical symbol over ISO green background
Viewing Distance	32 m
Warranty	1 year

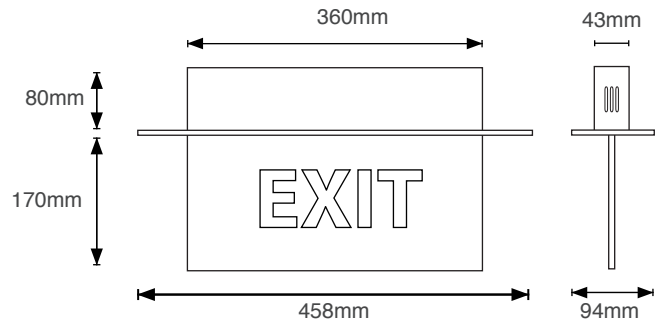

Ordering Information

MODEL	LEGEND	MODEL	LEGEND
EmEX R1602M		EmEX R1602RM	
EmEX R1602M-E		EmEX R1602RM-E	
EmEX R1602M-T		EmEX R1602RM-T	
EmEX R1602M-D (Double-sided with arrow)		EmEX R1602RM-D (Double-sided)	
EmEX R1602M-DX (Double-sided without arrow)		EmEX R1602RM-D-AD (Double-sided with arrow down)	
EmEX R1602RM-AD		EmEX R1602RM-D-AU (Double-sided with arrow up)	
EmEX R1602RM-AU		EmEX R1602RM-DX (Double-sided without arrow)	