

EmFLEX R1602M / RM Recessed Series

SLIM FLEX LED EMERGENCY EXIT SIGN

Features and Benefits

- All new slim and lightweight LED emergency exit signs with newly designed snap-on recess plate.
- Anti-corrosive housing, good for installation in high humidity and damp environment.
- Available in Exit or Running Man signage.
- Designed for seamless and hassle-free installation and maintenance.
- Samsung LED lamps provide high efficiency, durability and low energy consumption.

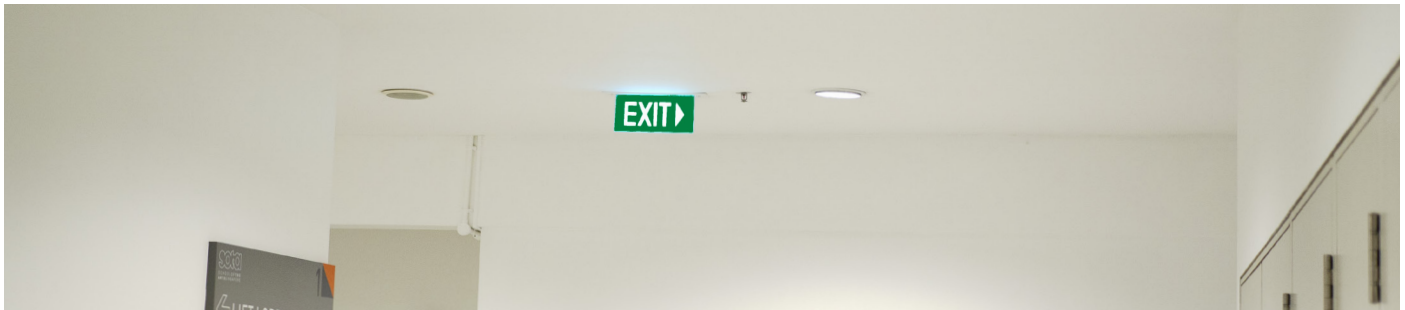

Technical Data

Mode of Operation	Maintained
Lamp	Samsung 2W High flux white LED
Operating Temperature	ta 0°C ~ 50°C
Mains Supply	230V AC 50Hz/60Hz
Power Consumption	Single-sided: < 4W Double-sided: < 5W
Battery	High temperature Ni-Cd battery
Charger	Fully automatic
Charging Monitor	Ø 5mm green LED
Recharge Period	24 hours
Testing Facility	Test-switch for independent testing
Emergency Duration	3 hours
Safety Feature	Low-voltage cut-off to prevent over-discharge of battery
Construction	Injection moulded fire retardant polycarbonate
Weight (Nett/Gross)	Single-sided: 0.7kg / 0.98kg Double-sided: 0.96kg / 1.16kg
Compliance	SS 563-1:2010 SS 563-2:2010/A1:2013 SS IEC 60598-2-22:2016
Installation	Recessed mounting
Cable Entry	3 x 20mm Ø knockout hole
IP Rating	IP30
Legend	White text/graphical symbol over ISO green background
Viewing Distance	30 m
Warranty	1 year

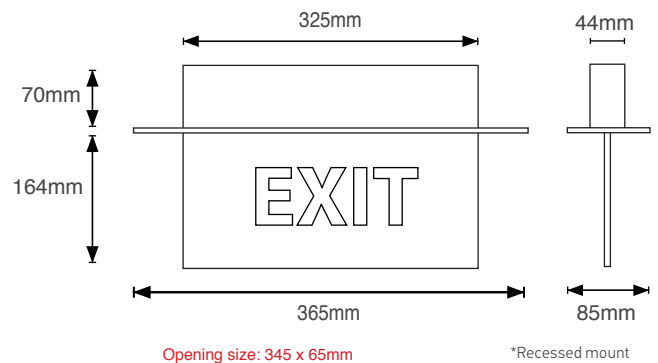

Ordering Information

MODEL	LEGEND	MODEL	LEGEND
EmFLEX R1602M		EmFLEX R1602RM	
EmFLEX R1602M-E		EmFLEX R1602RM-E	
EmFLEX R1602M-T		EmFLEX R1602RM-T	
EmFLEX R1602M-D (Double-sided with arrow)	 	EmFLEX R1602RM-D (Double-sided)	
EmFLEX R1602M-DX (Double-sided without arrow)	 	EmFLEX R1602RM-D-AD (Double-sided with arrow down)	
EmFLEX R1602RM-AD		EmFLEX R1602RM-D-AU (Double-sided with arrow up)	
EmFLEX R1602RM-AU		EmFLEX R1602RM-DX (Double-sided without arrow)	